

PARTS LIST FOR
3004 SERIES
PORTABLE/ALUMINUM
ELECTRIC DRIVEN/DIRECT DRIVE
COLD WATER PRESSURE WASHER

Motor Horsepower:	8.0 H.P.
Pump Oil Grade:	Pump Oil #AW-4085-0016
Pump Oil Capacity:	14 oz.
Nozzle Size:	4.5

This Parts Listing has been compiled for your benefit. You can be assured your new Cold Water Pressure Washer was constructed and designed with quality and performance in mind using over 25 years experience in the pressure washer business. Each component has been rigorously tested to insure the highest level of acceptance.

The contents of this Parts Listing are based on the latest product information available at the time of publication. The manufacturer reserves the right to make changes in price, color, materials, equipment, specifications or models at any time without notice.

WARNING

THIS IS A PROFESSIONAL HIGH PRESSURE, COLD WATER PRESSURE WASHER. CAUTION SHOULD BE OBSERVED WHEN USING OR REPAIRING THIS UNIT! READ AND FOLLOW THE SAFETY WARNINGS LISTED BELOW BEFORE ATTEMPTING ANY REPAIRS ON THIS PRESSURE WASHER!

SAFETY WARNINGS

1. NEVER alter or modify the equipment. Be sure any accessory items and system components being used will withstand the pressure developed. Use only genuine manufactured parts for repair of your pressure washer. Failure to do so can cause hazardous operating conditions and will VOID warranty.
2. NEVER make adjustments on machinery while the unit is connected to the engine without first removing the ignition cable from the spark plug. Turning over the machinery by hand during adjustment or cleaning might start the engine and machinery with it, causing serious injury to the operator.
3. Know how to stop and bleed pressures quickly. Be thoroughly familiar with controls.
4. Before servicing the unit, turn unit off, relieve the water pressure and allow the unit to cool down. Do not make repairs while the unit is running. Service in a clean, dry, flat area. Block the wheels to prevent the unit from moving. Be especially careful to properly dispose of any flammable materials.
5. After testing the machine, DO NOT leave the pressurized unit unattended. Shut off the unit and release trapped pressure before leaving.

Table of Contents

SPECIFICATIONS.....	3
FRAME ASSEMBLY PORTABLE.....	4
FRAME ASSEMBLY WALL MOUNT.....	6
PUMP ASSEMBLY (3-0410).....	8
UNLOADER ASSEMBLY (8-0361).....	10
WIRING SCHEMATIC.....	12
WIRING DIAGRAM.....	13

SPECIFICATIONS

MODEL	Portable	Wall Mount
Operating Pressure (PSI/Bar):	3000/206.8	
High Pressure Nozzle:	4.5	
Water Volume (GPM/lpm):	3.9/14.8	
Motor:	Totally enclosed fan cooled, circuit breaker thermal overload protection, 35ft. power supply cord with or without Ground Fault Circuit Interrupter (GFCI)	
Horsepower	8.0	
Voltage	230	
Phase	Single	
Amps	34.5	
Pump:	Direct Driven, Oil Bath, Triplex Piston	
Oil Type	Pump Oil #AW-4085-0016	
Oil Capacity (oz./liters)	14.0/0.41	
Plungers	Ceramic	
Manifold	Forged Brass	
Valves	Stainless Steel	
Unloader	Adjustable	
Thermal Relief Valve	Relieves heated water during unloader bypass stage	
Detergent Injector	Adjustable low pressure down stream from pump	
Unit Net Weight (lbs/Kg)	194 / 87.99	175 / 79.38
Unit Shipping Weight (lbs/Kg)	256.94 / 116.55	214.07 / 97.10
Unit Net Dimension (in/cm)	46.4L X 23.78W X 24.6H/117.86L X 60.40W X 62.48H	30.57L X 13.67W X 18.95H/77.65L X 34.72W X 48.13H
Unit Shipping Dimension (in/cm)	49L X 30W X 30H/124.46L X 76.20W X 76.20H	

FRAME ASSEMBLY PORTABLE

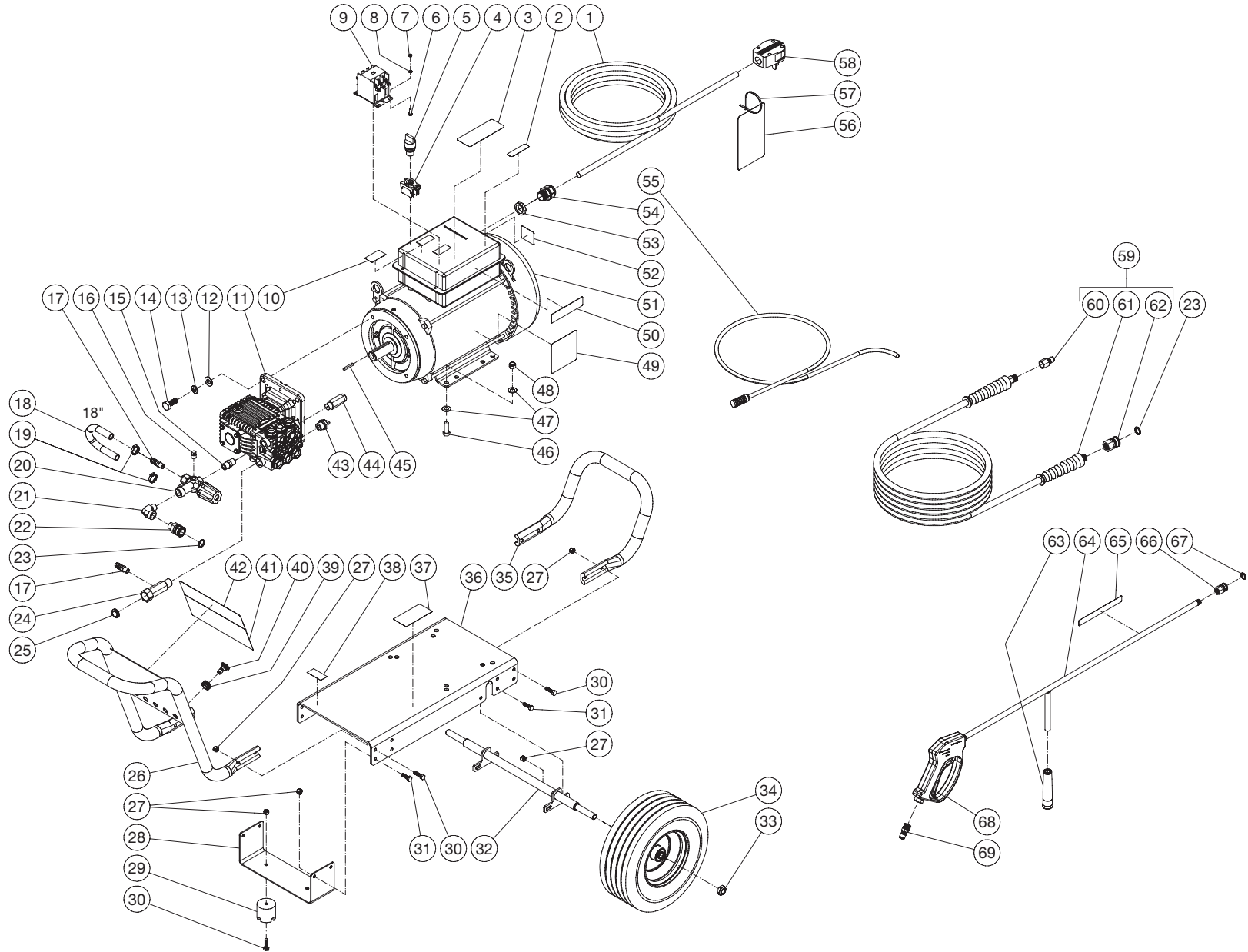

DC-3004-A0E2G 061917 JJR

FRAME ASSEMBLY								
ITEM	TITLE	PART #	QTY	ITEM	TITLE	PART #	QTY	
1	CORD *(THIRTY FIVE FEET REQUIRED)	32-0021	1	38	DECAL - MADE IN USA	34-3553	1	
2	DECAL - WARNING POTABLE WATER (E/S)	N/A	1	39	GROMMET	33-0001	5	
3	DECAL - WARNING RISK OF INJECTION/EXPLOSION (SEE 71-1064)	N/A	1	40	NOZZLE	18-0402	1	
4	SWITCH	32-0809	1	-	NOZZLE	18-0403	1	
5	SWITCH - ON/OFF	32-0808	1	-	NOZZLE	18-0404	1	
6	BOLT	27-9526	1	-	NOZZLE	18-0405	1	
7	NUT	30-6001	1	41	DECAL-WARN RISK OF ELECTRO E/S	N/A	1	
8	STAR WASHER	28-1009	1	42	DECAL - PLACARD SEE DX OPTION	N/A	1	
9	CONTACTOR	32-0811	1	43	RELIEF VALVE	22-0005	1	
10	DECAL - ON/OFF	N/A	1	44	SAFETY VALVE	22-0376	1	
11	PUMP	3-0410	1	45	KEY	43-0072	1	
12	WASHER	28-0006	4	46	BOLT	27-0167	4	
13	LOCKWASHER	29-0010	4	47	WASHER	28-0005	8	
14	BOLT	27-0217	4	48	LOCKNUT	30-0161	4	
15	NIPPLE	24-0010	1	49	DECAL - CAUTION/IMPORTANT (E/S)	N/A	1	
16	PLUG	23-0238	1	50	DECAL-3000 PSI (SEE 71-1064)	34-2899	1	
17	HOSE BARB	23-0120	2	51	MOTOR	2-0115	1	
18	HOSE *(TWO FEET REQUIRED)	15-0007	1	52	DECAL-CONNECT CIRCUIT BR. (SEE 71-1064)	N/A	1	
19	HOSE CLAMP	42-0011	2	53	ELECTRICAL LOCKNUT	32-0292	1	
20	UNLOADER	8-0361	1	54	CORD RELIEF	9-0046	1	
21	ELBOW	24-0105	1	55	DETERGENT HOSE	19-0233	1	
22	QUICK CONNECT SOCKET	17-0007	1	56	TAG - WARNING RISK OF ELECTROCUTION	34-1035	1	
23	O-RING	25-0123	1	57	CABLE TIE	33-0022	1	
24	INLET FITTING	23-0516	1	58	PLUG	32-0012	1	
25	FILTER	19-0001	1	59	HOSE ASSEMBLY	851-0338	1	
26	FRONT HANDLE	7-0265	1	60	QUICK CONNECT	17-0006	1	
27	LOCKNUT	30-0157	18	61	HOSE	15-0209	1	
28	UNDERBRACKET	56-0085	1	62	QC SOCKET	17-0004	1	
29	ISOLATOR	14-0008	2	63	GRIP	7-0002	1	
30	BOLT	27-0068	10	64	WAND (INCLUDES GRIP & QUICK CONNECT)	16-0418	1	
31	BOLT	27-0067	8	65	DECAL - RISK OF INJECTION (SEE 71-1064)	N/A	1	
32	AXLE	5-0361A53	1	66	QUICK CONNECT	17-0001	1	
33	LOCKNUT	30-0117	2	67	O-RING	25-0122	1	
34	WHEEL	14-0127	2	68	GUN	16-0483	1	
35	HANDLE	7-0266	1	69	QUICK CONNECT	17-0005	1	
36	BASEPLATE	5-0360	1	-		71-1064	1	
37	DECAL- SILVER STICKER	N/A	1	*MUST ORDER IN ONE FOOT LENGTHS				

FRAME ASSEMBLY WALL MOUNT

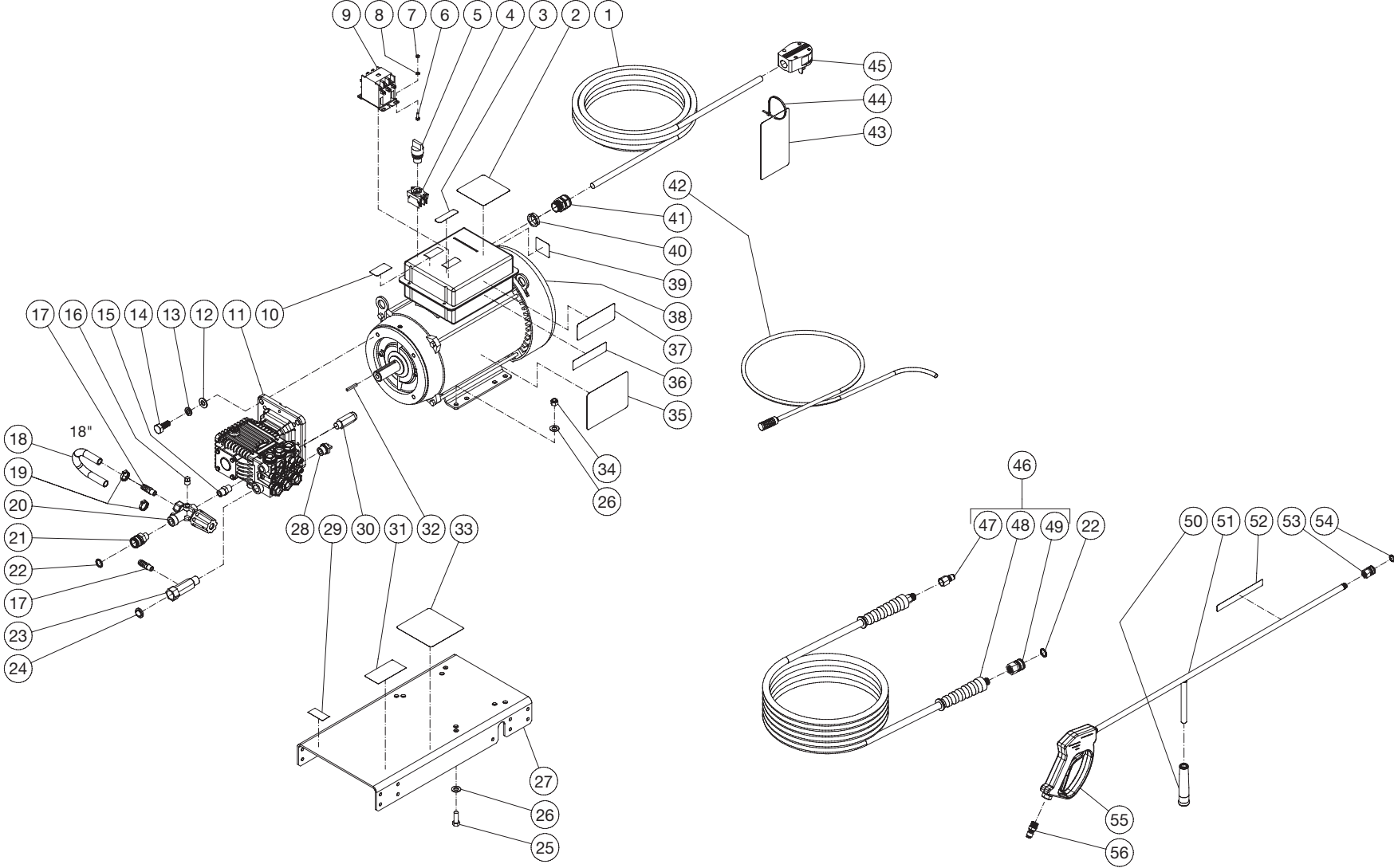

DC-3004-A0E2G-W 061917 JJR

FRAME ASSEMBLY							
ITEM	TITLE	PART #	QTY	ITEM	TITLE	PART #	QTY
1	CORD *(THIRTY FIVE FEET REQUIRED)	32-0021	1	30	SAFETY VALVE	22-0376	1
2	DECAL - CAUTION/IMPORTANT (E/S)	N/A	1	31	DECAL- SILVER STICKER	N/A	1
3	DECAL - WARNING POTABLE WATER (E/S)	34-1477	1	32	KEY	43-0072	1
4	SWITCH	32-0809	1	33	DECAL - WARNING RISK OF ELE. (E/S)	N/A	1
5	SWITCH - ON/OFF	32-0808	1	34	LOCKNUT	30-0161	4
6	BOLT	27-9526	1	35	DECAL - SEE DX OPTION	N/A	1
7	NUT	30-6001	1	36	DECAL-3000 PSI (SEE 71-0068)	34-2899	1
8	STAR WASHER	28-1009	1	37	DECAL - WARNING RISK OF INJECTION/EXPLOSION (SEE 71-0068)	N/A	1
9	CONTACTOR	32-0811	1	38	MOTOR	2-0115	1
10	DECAL - ON/OFF	N/A	1	39	DECAL-CONNECT CIRCUIT BR. (SEE 71-0068)	N/A	1
11	PUMP	3-0410	1	40	ELECTRICAL LOCKNUT	32-0292	1
12	WASHER	28-0006	4	41	CORD RELIEF	9-0046	1
13	LOCKWASHER	29-0010	4	42	DETERGENT HOSE	19-0233	1
14	BOLT	27-0217	4	43	TAG - WARNING RISK OF ELECTROCUTION	34-1035	1
15	NIPPLE	24-0010	1	44	CABLE TIE	33-0022	1
16	PLUG	23-0238	1	45	PLUG	32-0012	1
17	HOSE BARB	23-0120	2	46	HOSE ASSEMBLY	851-0338	1
18	HOSE *(TWO FEET REQUIRED)	15-0007	1	47	QUICK CONNECT	17-0006	1
19	HOSE CLAMP	42-0011	2	48	HOSE	15-0209	1
20	UNLOADER	8-0361	1	49	QC SOCKET	17-0004	1
21	QUICK CONNECT SOCKET	17-0007	1	50	GRIP	7-0002	1
22	O-RING	25-0123	1	51	WAND (INCLUDES GRIP & QUICK CONNECT)	16-0418	1
23	INLET FITTING	23-0516	1	52	DECAL - RISK OF INJECTION (SEE 71-0068)	N/A	1
24	FILTER	19-0001	1	53	QUICK CONNECT	17-0001	1
25	BOLT	27-0167	4	54	O-RING	25-0122	1
26	WASHER	28-0005	8	55	GUN	16-0483	1
27	BASEPLATE	5-0360	1	56	QUICK CONNECT	17-0005	1
28	RELIEF VALVE	22-0005	1	-	DECAL SET	71-0068	1
29	DECAL - MADE IN USA	34-3553	1	*MUST ORDER IN ONE FOOT LENGTHS			

PUMP ASSEMBLY (3-0410)

TORQUE SPEC.		
POSITION	FT-LBS	NM
1	14.7	20
2	14.7	20
4	95.9	130
10	29.4	40
11	29.4	40
20	7.3	10
28	7.3	10
40	11.0	15
47	7.3	10

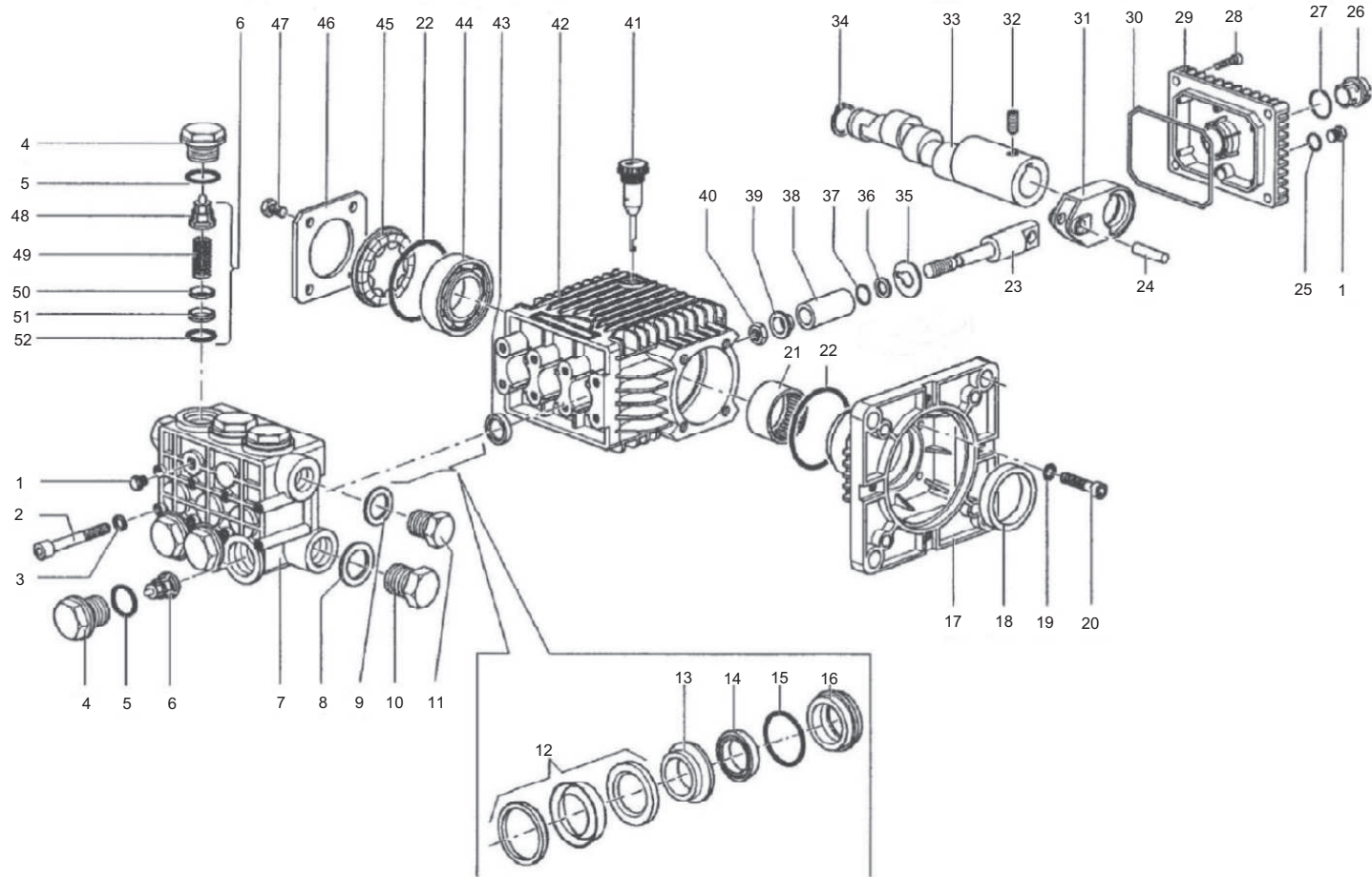

PUMP ASSEMBLY

ITEM	DESCRIPTION	PART #	QTY	ITEM	DESCRIPTION	PART #	QTY
1	PLUG	39-0017	2	27	O-RING	25-0059	1
2	BOLT	27-9576	8	28	BOLT	27-8401	4
3	LOCKWASHER	29-1014	8	29	CRANKCASE COVER	46-1164	1
4	VALVE PLUG (SEE KIT 70-0668)	39-0071	6	30	O-RING	25-0317	1
5	O-RING (SEE KIT 70-0668)	25-0012	6	31	CONNECTING ROD	46-1160	3
6	VALVE ASSEMBLY (SEE KIT 70-0028)	70-0028	6	32	SET SCREW	N/A	1
7	MANIFOLD	N/A	1	33	CRANKSHAFT	N/A	1
8	WASHER	28-1038	1	34	SNAP RING	46-0104	1
9	WASHER	28-1002	1	35	SLINGER WASHER	28-1049	3
10	PLUG	39-0019	1	36	ANTI-EXTRUSION RING	25-0143	3
11	PLUG	39-0018	1	37	O-RING	N/A	3
12	PACKING ASSEMBLY (SEE KIT 70-0670 OR 70-0671)	N/A	3	38	PISTON	46-0603	3
13	RING (SEE KIT 70-0671)	N/A	3	39	WASHER GASKET	46-1231	3
14	LP SEAL (SEE KIT 70-0670 OR 70-0671)	N/A	3	40	NUT	46-0168	3
15	O-RING (SEE KIT 70-0671)	N/A	3	41	DIPSTICK	46-0143	1
16	SEAL RETAINER (SEE KIT 70-0671)	N/A	3	42	CRANKCASE	46-1166	1
17	FLANGE	N/A	1	43	OIL SEAT (SEE KIT 70-0414)	N/A	3
18	OIL SEAL	26-0181	1	44	BALL BEARING	48-0011	1
19	WASHER	28-0200	4	45	OIL LEVEL INDICATOR SPACER	46-0574	1
20	BOLT	27-8404	4	46	OIL LEVEL RETAINER SPACER	46-0084	1
21	NEEDLE BEARING	48-0040	1	47	BOLT	27-8000	8
22	O-RING	25-0060	2	48	VALVE CAGE	N/A	6
23	PLUNGER GUIDE	46-1165	3	49	SPRING	N/A	6
24	PIN	46-1162	3	50	VALVE PLATE	N/A	6
25	O-RING	25-0210	1	51	VALVE SEAT	N/A	6
26	SIGHT GLASS	46-1163	1	52	O-RING	25-0053	6

REPLACEMENT KITS

KIT #	DESCRIPTION	ITEMS	# OF ASSEMBLIES	# OF CYLINDERS
70-0028	KIT - VALVE	6	6	3
70-0668	KIT - VALVE PLUG	4,5	6	3
70-0414	KIT - OIL SEAL	43	3	3
70-0670	KIT - PACKING SEALS	12,14	3	3
70-0671	KIT - PACKING W/BRASS 18mm	12,13,14,15,16	1	1

UNLOADER ASSEMBLY (8-0361)

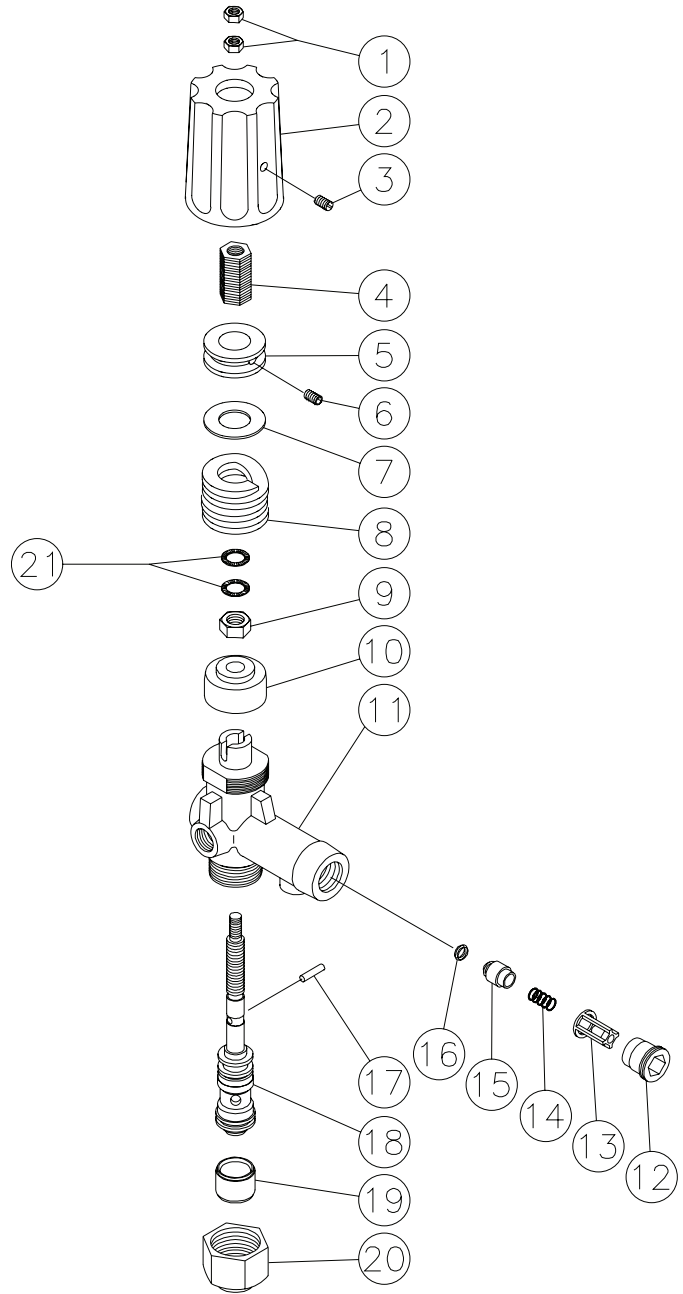

UNLOADER (850-0252)			
REF. #	DESCRIPTION	PART #	QTY.
1	Hex Nut	8-0362	2
2	Cover	7-0098	1
3	Set Screw	27-4280	1
4	Adjusting Insert- Brass	8-0363	1
5	Adjustment Nut	8-0364	1
6	Set Screw	8-0365	1
7	Glide Ring	8-0366	1
8	Spring	49-0104	1
9	Hex Nut	8-0367	1
10	Bushing	8-0368	1
11	Unloader Body	8-0369	1
12	Retainer	8-0269	1
13	Valve Housing	8-0104	1
14	Spring	49-0023	1
15	Valve	8-0105	1
16	O-ring	25-0036	1
17	Cylinder Pin	8-0372	1
18	Piston Repair Kit	70-0243	1
19	Spacer	8-0371	1
20	Stop Nut	8-0157	1
21	Washer	29-0154	2
	Check Valve Repair Kit (Includes 13-16)	70-0244	
	Unloader Complete	850-0252	

WIRING SCHEMATIC

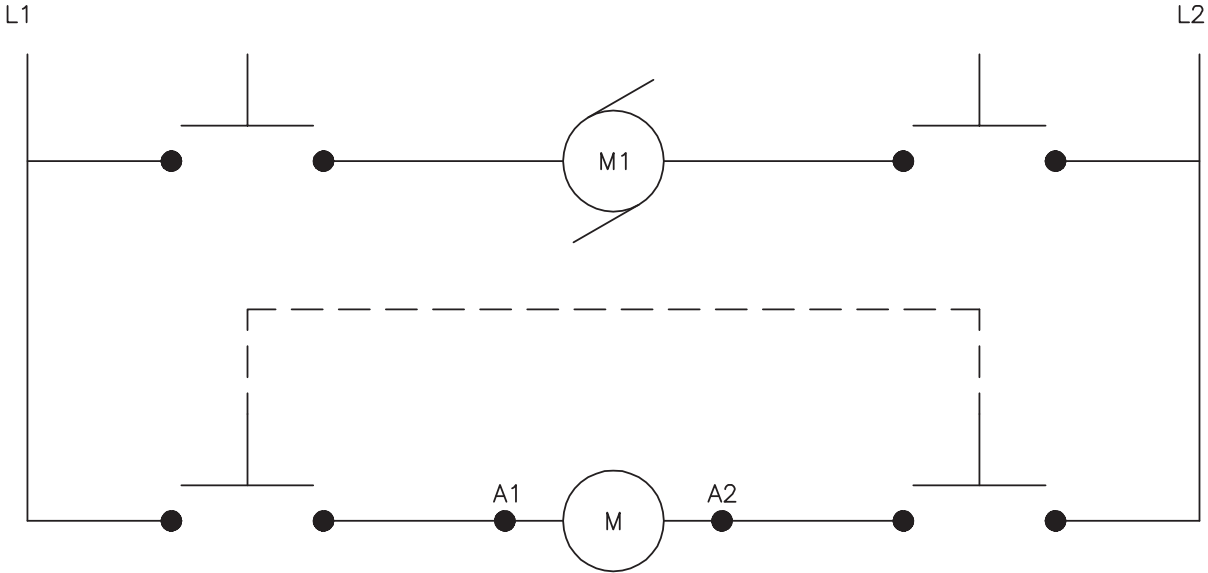

GC/JP-2503/3004-1ME1_0ME1 WIRE SCHEMATIC-070704-AJG

WIRING SCHEMATIC			
REF. #	DESCRIPTION	PART #	QTY.
-	Wire 16 Gauge- Red *(Two Feet Required)	32-0092	1
-	Wire 16 Gauge- Yellow *(Two Feet Required)	32-0095	1
-	Cable Tie	32-0022	1
*Must Order in One Foot Lengths			

GC/JP-2503/3004-1ME1/0ME1 WIRE SCHEMATIC-070704-AJG

WIRING DIAGRAM

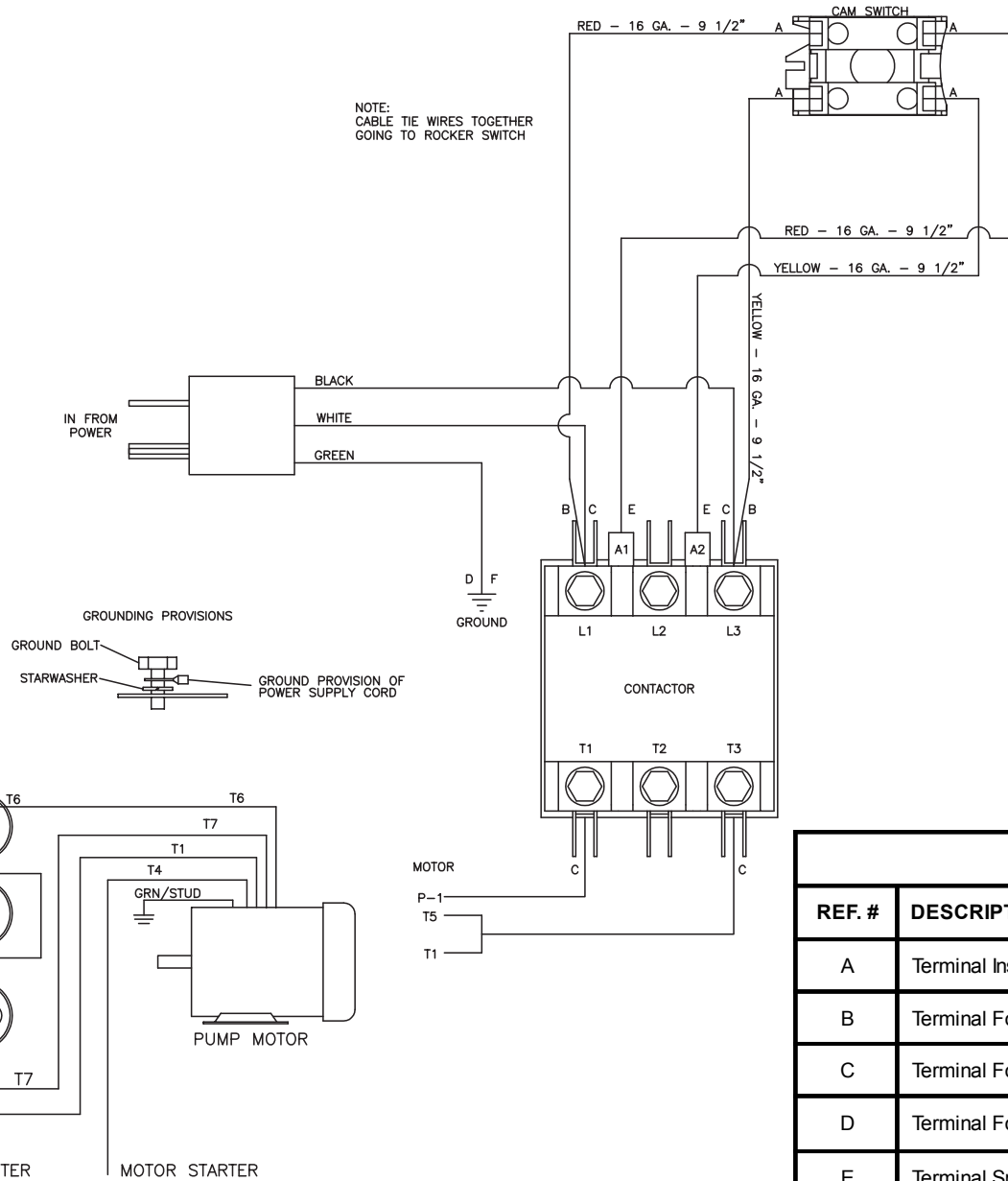

GC/JP-2503/3004-0ME1/0ME1 WIRE
DIAGRAM-070704-AJG

GC-JP-2503/3004-1ME1_0ME1 WIRE DIAGRAM-070704-AJG

WIRING DIAGRAM			
REF. #	DESCRIPTION	PART #	QTY.
A	Terminal Insulated- Black	32-0494	4
B	Terminal Fork- 14GA	32-0003	2
C	Terminal Fork- 10GA	32-0034	4
D	Terminal Fork- 10GA	32-0639	1
E	Terminal Spade- 14GA	32-0221	2
F	Lockwasher	29-0154	1

